

19.4" Modero® X Series Panoramic Tabletop Touch Panel no Camera, no Microphone

MXT-1900L-PAN-NC (FG5968-21) Tabletop Touch Panel no Camera, no Microphone



Overview

See more and do more with the most elegant interface designed specifically for dedicated room control. The MXT-1900L-PAN-NC is designed to exclude the camera, Near Field Communication (NFC), microphone and Bluetooth capabilities of the original Modero X Series panel to meet the security requirements of facilities that do not allow these capabilities.

Modero X Series Touch Panels provide several industry firsts including a beautiful, panoramic capacitive multi-touch screen that provides users access to multiple applications with minimal navigation. The distinctive, low-profile design is engineered to sit perfectly on a table without obstructing views. Modero X Series is the control surface that simply delivers more.

Common Applications

The MXT-1900L-PAN-NC is ideal for federal, state, and local government or military facilities with strict security restrictions due to the storage, use, discussion or electronic processing of sensitive or classified information. It features modifications to support the added security measures necessary in secure environments such as sensitive compartmented information facilities, emergency operations centers or command headquarters. These modified panels give users robust functionality and capabilities while adhering to essential operational security guidelines.

Features

- **Panoramic Control Surface** – Combined with the new PanTastic UI, the panoramic touch panels take the user experience to a whole new level with an impressive control surface to perform activities much in the same way you use a computer – multi-tasking with dedicated spaces
- **Graphic Leaps & Bounds** – The Modero X Series includes some striking new intuitive UI functionality including: gesturing, swiping, dynamic reordering and enhanced animation capabilities

- **Perfect From Any Angle** – Includes In-Plane Switching (IPS), the latest technology in popular tablet/mobile devices that delivers the widest viewing angles and the most accurate color reproduction on the market

Dealer Benefits

- **Attract Specialized Customers** - The elegant design and robust security modifications are ideal for niched customers increasing the breadth and depth of dealers’ current customer portfolio
- **Address Unique Requirements** – With a panoramic profile, the Modero X Series provides dealers with a solution for unique uses where multiple applications must be viewed simultaneously
- **Differentiate Yourself** – The Modero X Series offers design and technology features unmatched in the industry

Customer Benefits

- **Designed for Restricted Environments** – The modified features of this Modero X touch panel support the added security measures of many government and military facilities. Two-way transmission has been removed/disabled prohibiting any potential security threats
- **Multi-Task Capability** – The contemporary design provides a large control surface, which allows multiple views for different activities such as presenting, controlling and previewing
- **Simple to Use Interfaces** – The capacitive multi-touch screen combined with intuitive user-interfaces makes it easy for anyone to operate sophisticated meeting room equipment
- **Sleek, Low-Profile Design** - The Modero X Series is engineered to sit perfectly on a table without obstructing views

Specifications

| TOUCH SCREEN DISPLAY | |
|-----------------------------|--|
| Display Type | TFT Active Matrix Color LCD with In-plane Switching Technology (IPS) |
| Display Size (WH) | Landscape: 20.4" x 6.9" (519 mm x 175 mm), 20.4" (518 mm) diagonal |
| Viewable Area (WH) | Landscape: 18.7" x 5.9" (475 mm x 151 mm), 19.4" (493 mm) diagonal |
| Resolution (WH) | Landscape: 1920x530 |
| Aspect Ratio (WH) | Landscape: 18:5 |
| Brightness | 350 cd/m2 |
| Contrast Ratio | 1000:1 |
| Color Depth | 16.7M colors |
| Illumination | LED |
| Touch Overlay | Projected Capacitive, multi-touch support, 3 simultaneous max |
| Viewing Angle | Vertical ± 89°, Horizontal ± 89° |

| MEMORY | |
|----------------------|--------------------------------|
| SDRAM | 512 MB |
| Flash | 4 GB |
| Maximum Project Size | 2.4 GB flash available to user |

| COMMUNICATIONS | |
|-----------------------|---|
| ETHERNET | 10/100 port, RJ-45 connector. Supported IP and IP-Based Protocols: UCP, TCP, ICMP, ICSP, IGMP, DHCP, Telnet, FTP, DNS, RFB (for VNC), HTTP |
| USB | (3) USB host 2.0, Type A ports: Firmware upgrade, Touch Panel File Transfer, JPEG Image Viewer, HID Peripherals, USB Audio Output for Headsets (1) Micro-USB device port: Disabled |

| VIDEO | |
|------------------------------------|--|
| Supported Video Codecs | MPEG2-TS: MPEG-2 Main Profile @High Level up to 720p at 25 fps (decode only) MPEG-2-TS: H.264 High Profile @Layer 4, AAC-LC up to 720p at 25 fps (decode) MJPEG up to 720p at 25 fps (decode only) |
| Supported Video Transport Streams | MPEG-TS for MPEG2 and H.264; HTTP for MJPEG |
| Max Number of Active Video Streams | One decode |

| AUDIO | |
|------------------------|---|
| Speakers | 4 ohm, 2 Watt, 300Hz cutoff frequency |
| Supported Audio Codecs | MP2 Layer I and II, MP3 (8 kHz, 11.025 kHz, 12 kHz, 16 kHz, 22.05 kHz, 24 kHz, 32 kHz, 44.1 kHz, 48 kHz) AAC-LC (8 kHz, 96 kHz) G.711 with μ Law (decode at 8kHz) |
| File Formats | WAV, MP3 (as part of touch panel file only - no USB storage) |

| GRAPHICS ENGINE | |
|-----------------|--|
| AMX G4 | G4 enhanced feature set supporting multi-touch and gestures, scrolling, transitions - See TPD4 Operations Guide for more information |

| EMBEDDED APPLICATIONS | |
|-----------------------|---|
| Remote Management | VNC Server, G4 Web Control, AMX Resource Management Suite |

| FRONT PANEL COMPONENTS | |
|------------------------|---|
| Light Sensor | Photosensitive light detector for automatic adjustment of the panel brightness |
| Proximity Detector | Max range = ~3', typ range = ~1', FOV = ~10 degrees |
| Sleep Button | Sleep button to activate sleep mode and powering off. Also provides access to setup pages (can be disabled) |

| CONNECTIONS | |
|-------------|---|
| Ethernet | 10/100 port, RJ-45 connector |
| USB | (3) USB host 2.0, Type A ports (1) Micro USB device port: Disabled |
| Power | 2-pin, locking 3.5mm Phoenix connector |

| ENVIRONMENTAL | |
|----------------------------|--|
| Temperature (Operating) | 32° F to 104° F (0° C to 40° C) |
| Temperature (Storage) | 4° F to 140° F (-20° C to 60° C) |
| Humidity (Operating) | 20% to 85% RH |
| Humidity (Storage) | 5% to 85% RH |
| Power ("Heat") Dissipation | On: 109.2 BTU/hr, Standby: 10.6 BTU/hr |

| GENERAL | |
|--------------------------------|--|
| Dimensions (HWD) | 7" x 20 3/8" x 5 5/16" (177 mm x 519 mm x 135 mm) |
| Weight | 9.4 lbs (4.26 Kg) |
| Power Consumption | Full-On: 32W (12 VDC, 2.7 A), Standby: 3.10 W (12 VDC, 0.3 A) |
| Start-Up Inrush Current | 40 A for 80 μ sec |
| External Power Supply Required | Requires one of these AMX power sources (not included): PSN4.4 Power Supply, 4.4 A, 3.5 mm Phoenix, 13.5 VDC (FG423-45) MXA-MPL Modero X Series Multi Preview Live (FG5968-10) MXA-MP Modero X Series Multi Preview (FG5968-20) |
| Certifications | FCC Part 15 Class B C-Tick CISPR 22 Class B CE EN 55022 Class B and EN 55024 CB Scheme IEC 60950-1 IC IEC/EN-60950 RoHS/WEEE compliant |
| Included Accessories | Locking 2-pin Phoenix mate (41-0002-SA) MXA-USB-C, USB Port Cover Kit, Modero X Series Touch Panel (FG5968-18) HPG-10-10K, 3/4" Mini-Grommet (FG570-01) MXA-CLK, Modero X Series Cleaning Kit (FG5968-16) |
| Optional Accessories | MXA-MP, Modero X Series Multi Preview (FG5968-20) MXA-MPL, Modero X Series Multi Preview Live (FG5968-10) Power supply, 4.4A, 3.5mm Phoenix, 13.5VDC (FG423-45) HPG-10-10K, Mini-Grommet, 10-Pack (FG570-01-10K) MXA-CLK, Modero X Series Cleaning Kit (FG5968-16) MXA-USB-C, USB Port Covers for the Modero X Series Touch Panels (FG5968-18) CSG, Communications Gateway (FG2182-01, -02, -03) |

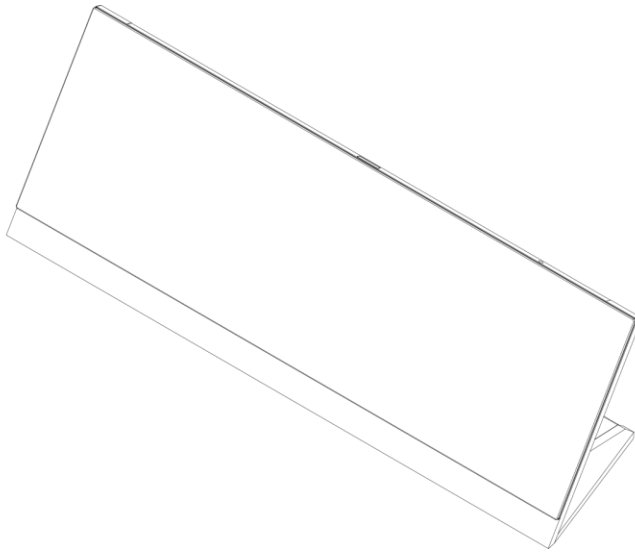

MXT-1900XL-PAN
(Isometric View)

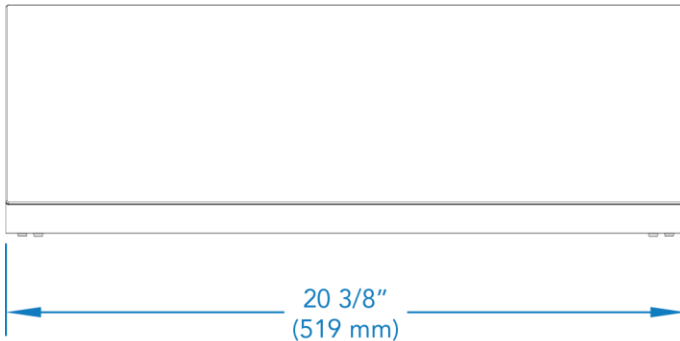

MXT-1900XL-PAN
(Front View)

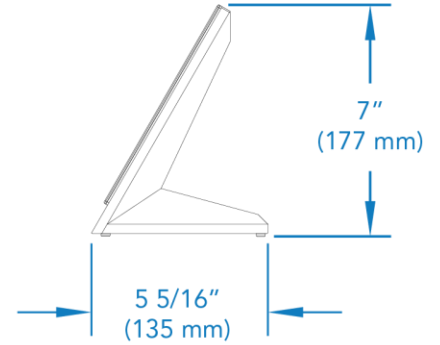

MXT-1900XL-PAN
(Right View)

About AMX

AMX hardware and software solutions simplify the implementation, maintenance, and use of technology to create effective environments. With the increasing number of technologies and operating platforms at work and home, AMX solves the complexity of managing this technology with reliable, consistent and scalable systems. Our award-winning products span control and automation, system-wide switching and audio/video signal distribution, digital signage and technology management. They are implemented worldwide in conference rooms, homes, classrooms, network operation / command centers, hotels, entertainment venues, broadcast facilities, and more. ©2012 AMX. All rights reserved. Specifications subject to change. Revised 8-Oct-12.

AMX.com | 800.222.0193 | 469.624.8000 | +1.469.624.7400 | fax 469.624.7153